

Industrial Tumble Dryers

LS 250, LSMS 13, LS 300, LSD 300, LS 350



FEATURES

- Standard stainless steel drum with large diameter
- Easy to use microprocessor
- Combination of Radial and Axial airflow - RADAX® concept:
 - maximal heat transfer
 - low energy consumption
 - short drying time
- Large door opening for easy loading and unloading

OPTIONS

- Coin operated version
- Reversing drum
- Full Control programmer
- Residual moisture control Sensodry®:
 - safe drying of delicate linen
 - humidity detection in %
 - ideal in combination with SoftWash®
 - ideal for dry cleaners, fire depts
 - available on Easy and Full Control
- Stainless steel front



LSD 300



LSMS 13

TYPE		LS 250	LSMS 13	LS 300	LSD 300	LS 350
CAPACITY						
Drum capacity	kg/lb	11/24	13/27	13/27	2x13/2x27	16/35
Drum volume	l	250	285	285	2x285	345
Drum diameter	mm	Ø760	Ø760	Ø760	2xØ760	Ø760
Number of drums		1	1	1	2	1
Number of loading doors		1	1	1	2	1
AIRFLOW	m ³ /h	650-680	630-760	630-760	2x630-760	830-940
DRYING AVERAGE	g/min	190	225	225	2x225	300
MOTORS						
Fan	kW	0,55	0,55	0,55	2x0,55	0,55
Drive	kW	0,25	0,25	0,25	2x0,25	0,25
GAS HEATING						
Gas connection	NPT	3/4"	3/4"	3/4"	2x3/4"	3/4"
Electrical connection		3x220-240V 50Hz, 1x220-240V 50Hz, 3x380-415V 50Hz				
Energy	kW	16,5	19,5	19,5	2x19,5	25
	kBTU/h	56,3	66,5	66,5	2x66,5	85,3
STEAM HEATING						
Steam connection	NPT	3/4"		3/4"	2x3/4"	3/4"
Electrical connection		3x220-240V 50Hz, 1x220-240V 50Hz, 3x380-415V 50Hz				
Steam output *	kW	16,5-22		19,5-27	2x19,5-27	22-32
Steam pressure	bar	3-6/7-10		3-6/7-10	3-6/7-10	3-6/7-10
ELECTRICAL HEATING						
Electrical connection		3x220-240V 50Hz, 3x380-415V 50Hz				
Energy	kW	13,5	18,0	18,0	2x18,0	24,0
PROGRAMMER						
Easy control - antivandal		Standard	Standard (No coin)	Standard	Standard	Standard
Full control		Available	Available	Available	Available	Available
EXHAUST	mm	200				
DIMENSIONS						
Size HxWxD	mm	1680x795x1070	1075x795x1240	1680x795x1160	2030x795x1240	1680x795x1280
TRANSPORT DATA						
Gross weight	kg	240	200	265	385	270
Net weight	kg	230	185	250	370	250
Packed HxWxD	mm	1785x855x1100	1160x880x1325	1785x855x1190	2120x880x1325	1785x855x1310

* Steam output is fl exible depending on steam pressure, The data concerning dimensions of machines include all extended parts

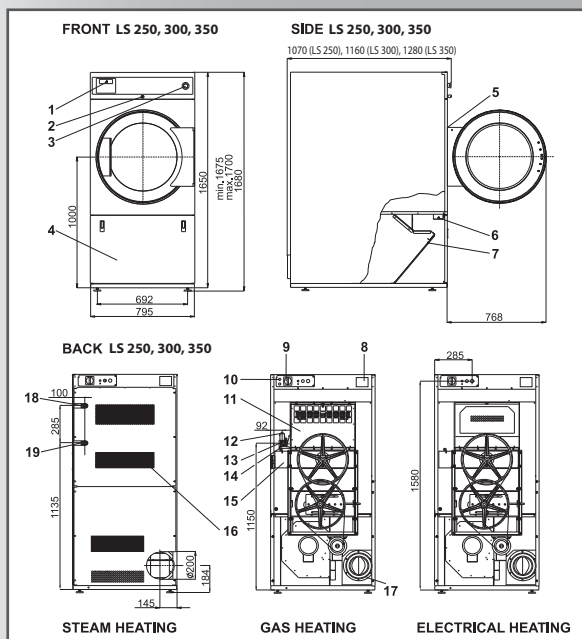

1. Programmer
2. Lock of the control panel
3. Emergency stop button (not applicable for version with coin meter)
4. Lint screen cover
5. Door lock microswitch
6. Lint cover microswitch
7. Lint screen
8. Name plate
9. Main switch
10. Main power supply
11. Heating chamber
12. Gas valve (G models only)
13. Pressure regulator (G models only)
14. Gas supply (G models only)
15. Airflow switch
16. Suction
17. Exhaust piping
18. Steam supply
19. Condense drain

Lavamac preserves the right to change the machines and the specification in this leaflet at any time, without prior notice. Details and photographs are only for information and never binding.

www.lavamac.eu



05-2010/532452